



US 20150064819A1

(19) **United States**

(12) **Patent Application Publication**
LEE

(10) **Pub. No.: US 2015/0064819 A1**
(43) **Pub. Date: Mar. 5, 2015**

(54) **METHOD FOR MANUFACTURING ORGANIC LIGHT EMITTING DIODE DISPLAY**

Publication Classification

(71) Applicant: **SAMSUNG DISPLAY CO., LTD.**,
Yongin-City (KR)

(51) **Int. Cl.**
H01L 51/56 (2006.01)

(72) Inventor: **Kang-Yong LEE**, Seoul (KR)

(52) **U.S. Cl.**
CPC **H01L 51/56** (2013.01); **H01L 2227/323**
(2013.01); **H01L 2227/326** (2013.01)

USPC **438/28**

(21) Appl. No.: **14/475,933**

(57) **ABSTRACT**

(22) Filed: **Sep. 3, 2014**

A manufacturing method of an organic light emitting device may include the following. A panel displaying an image is formed. A buffering member including a dummy buffering member is adhered to the panel. A film is adhered to an upper surface of the buffering member. The film and the dummy buffering member are removed.

(30) **Foreign Application Priority Data**

Sep. 4, 2013 (KR) 10-2013-0106239

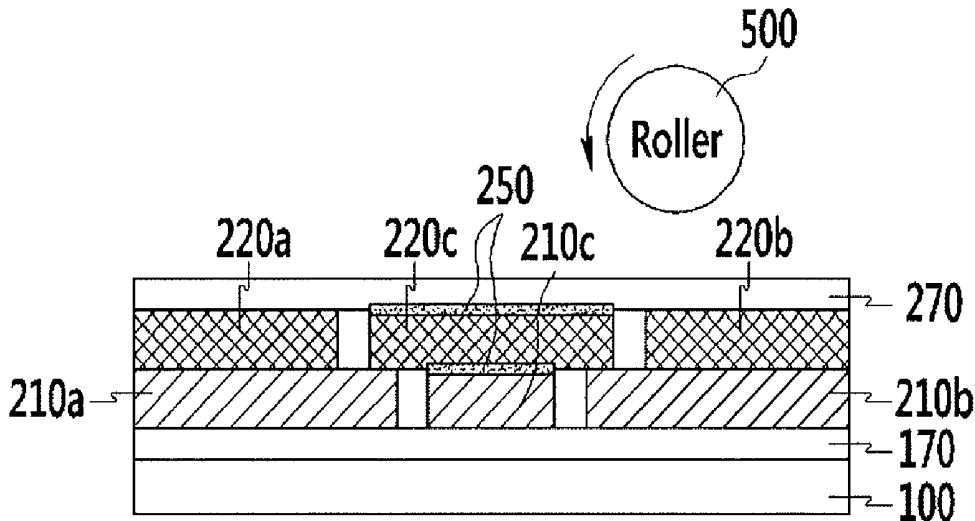

FIG. 1

1000

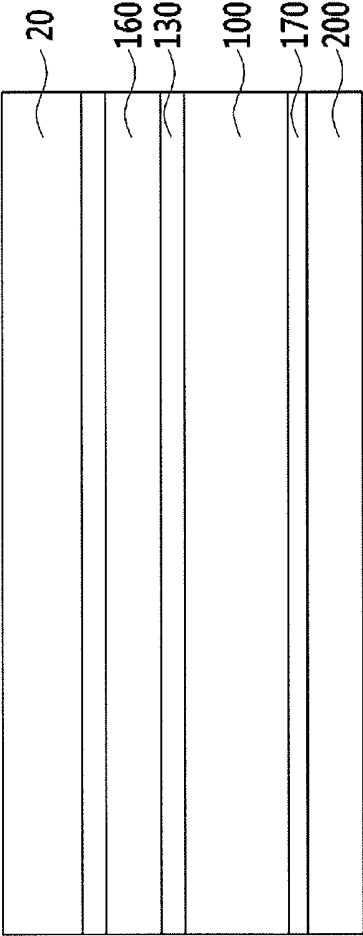

FIG. 2

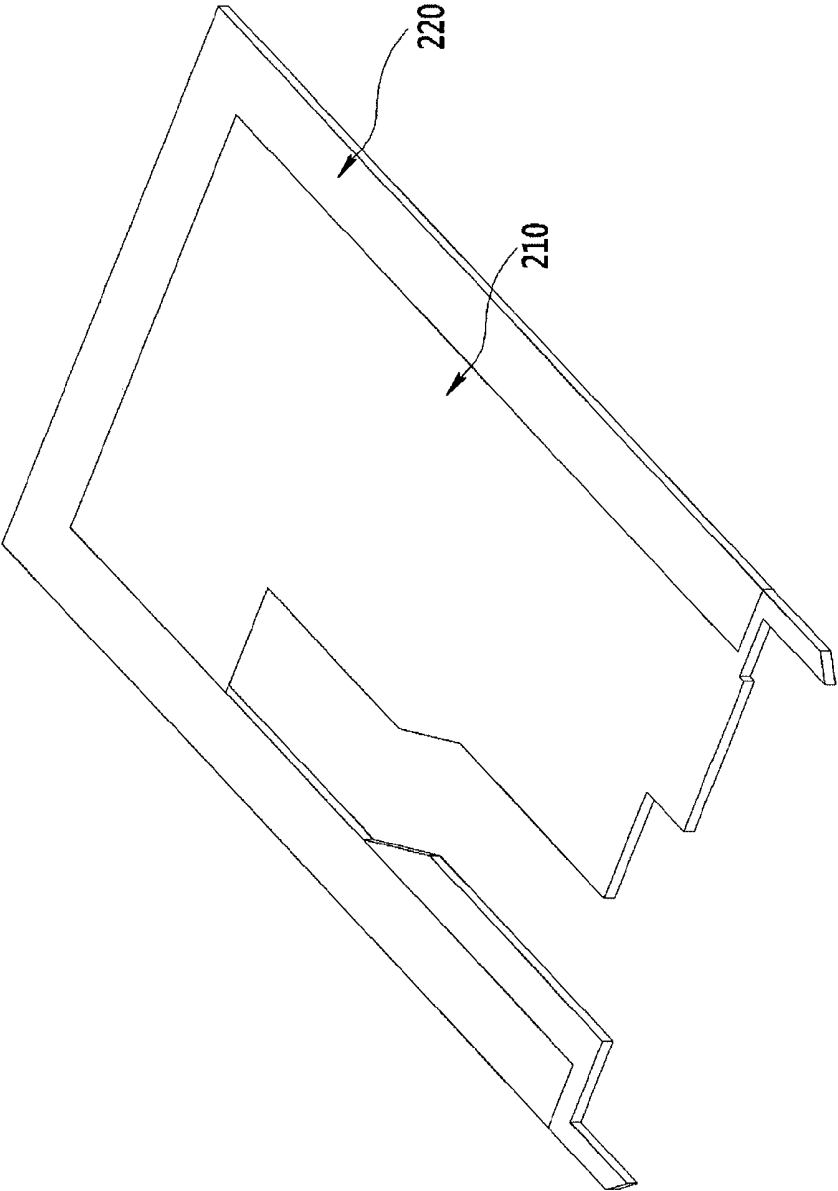

FIG. 3

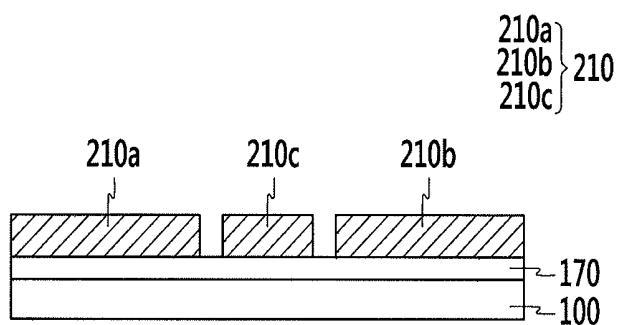

FIG. 4

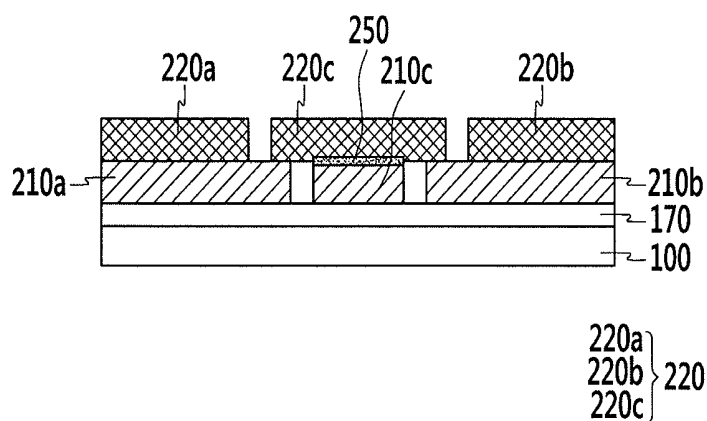

FIG. 5

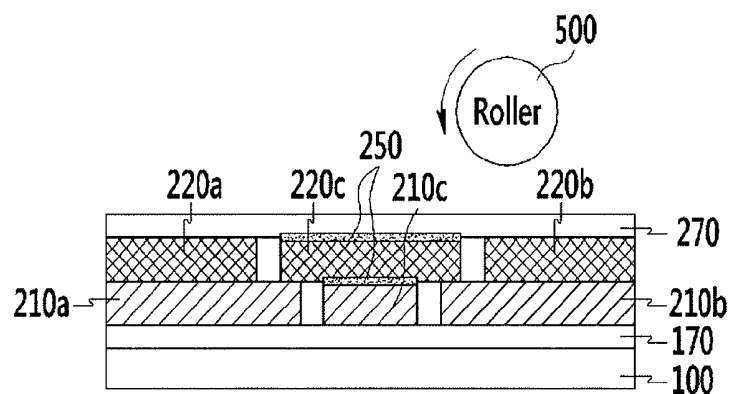

FIG. 6

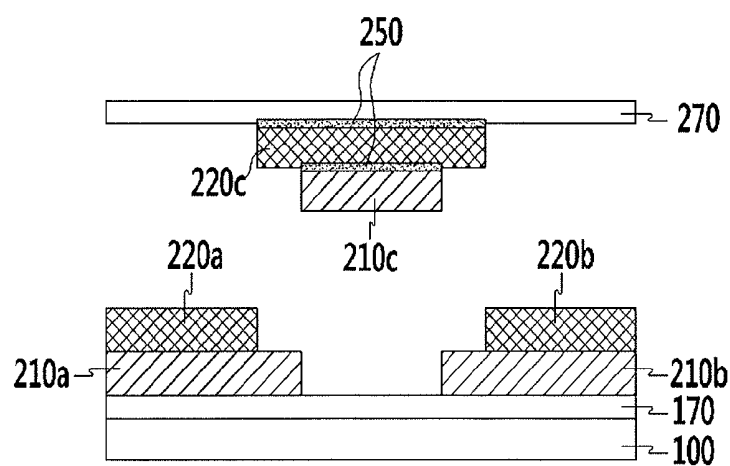

FIG. 8

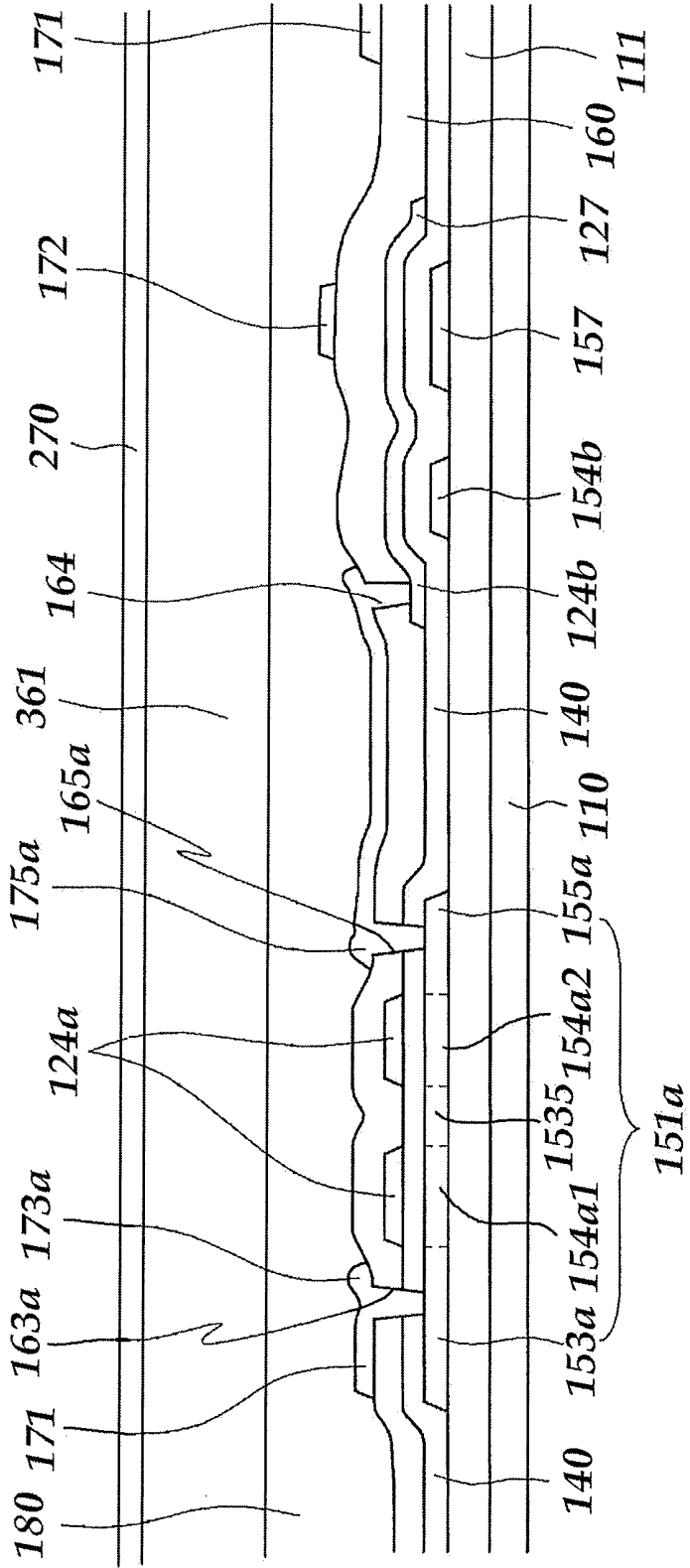
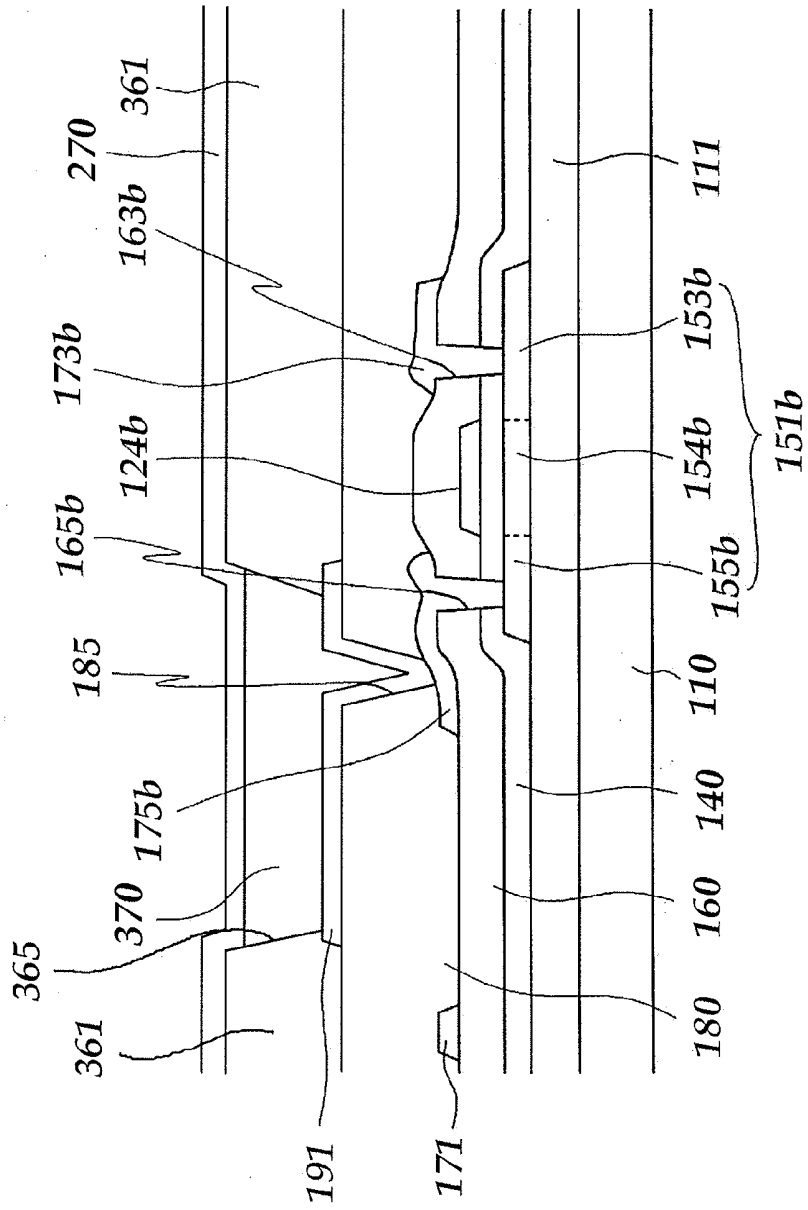

FIG. 9



METHOD FOR MANUFACTURING ORGANIC LIGHT EMITTING DIODE DISPLAY

CROSS-REFERENCE TO RELATED APPLICATION

[0001] Korean Patent Application No. 10-2013-0106239, filed on Sep. 4, 2013, in the Korean Intellectual Property Office, and entitled: "Method For Manufacturing Organic Light Emitting Diode Display," is incorporated by reference herein in its entirety.

BACKGROUND

[0002] 1. Field

[0003] Embodiments relate to a manufacturing method of an organic light emitting device.

[0004] 2. Description of the Related Art

[0005] An organic light emitting diode (OLED) display is a flat panel display that can be lightweight and slim because it has a self-light emitting characteristic and does not require a separate light source. Because it shows characteristics such as low power consumption, high luminance, and high reaction speed, it is receiving attention as the next generation display device. An OLED display may include a panel assembly forming an organic light emitting diode. The organic light emitting diode may include an anode, a cathode, and an organic emission layer. Holes and electrons may be injected from the anode and cathode to form excitons, which emit light while transiting to a ground state.

SUMMARY

[0006] A manufacturing method of an organic light emitting device may include the following. A panel displaying an image is formed. A buffering member including a dummy buffering member is adhered to the panel. A film is adhered to an upper surface of the buffering member. The film and the dummy buffering member are removed. After adhering the buffering member, an upper portion of the film may be pressed in a panel direction by using a roller. Before adhering the buffering member, a buffer layer may be formed on the panel. The buffering member may include a urethane-based or acryl-based material. The film may include polyethylene terephthalate (PET). A density of the buffering member may be the same or different according to positions thereof. An adhesive may be coated on one surface of the buffering member facing the panel, and the adhesive may be coated on a contact portion of the dummy buffering member with the film.

[0007] The buffering member may be formed as dual layers including a first buffering member and a second buffering member. The first buffering member may include a first dummy buffering member. The second buffering member may include a second dummy buffering member. The second buffering member may be adhered to the upper surface of the first buffering member. The film may be adhered to the upper surface of the second buffering member. The first buffering member and the second buffering member may include the same material and/or different materials. The first buffering member and the second buffering member may have the same height and formation position, and/or different heights and formation positions. The first dummy buffering member and the second dummy buffering member may be adhered to each

other, and the dummy buffering member may be adhered to the film to be removed. The buffering member may include two or more layers.

BRIEF DESCRIPTION OF THE DRAWINGS

[0008] Features will become apparent to those of ordinary skill in the art by describing in detail exemplary embodiments with reference to the attached drawings in which:

[0009] FIG. 1 schematically illustrates a cross-sectional view of an organic light emitting device.

[0010] FIG. 2 illustrates a perspective view of a multi-cushion.

[0011] FIG. 3 to FIG. 6 illustrate views showing stages of a manufacturing process of a buffering member of an organic light emitting device.

[0012] FIG. 7 illustrates a layout view of an organic light emitting device.

[0013] FIG. 8 illustrates a cross-sectional view of the organic light emitting device of FIG. 7 taken along the line II-II.

[0014] FIG. 9 illustrates a cross-sectional view of the organic light emitting device of FIG. 7 taken along the line

DETAILED DESCRIPTION

[0015] Example embodiments will now be described more fully hereinafter with reference to the accompanying drawings; however, they may be embodied in different forms and should not be construed as limited to the embodiments set forth herein. Rather, these embodiments are provided so that this disclosure will be thorough and complete, and will fully convey exemplary implementations to those skilled in the art. In the drawing figures, the dimensions of layers and regions may be exaggerated for clarity of illustration. When a layer or element is referred to as being "on" another layer or substrate, it can be directly on the other layer or substrate, or intervening layers may also be present. When a layer is referred to as being "under" another layer, it can be directly under, and one or more intervening layers may also be present. When a layer is referred to as being "between" two layers, it can be the only layer between the two layers, or one or more intervening layers may also be present. Like reference numerals refer to like elements throughout.

[0016] FIG. 1 illustrates a schematically cross-sectional view of an organic light emitting device 1000. Referring to FIG. 1, the organic light emitting device 1000 may include a panel 100 combined with a sealing member, a buffer layer 170, a buffering member 200, a polarization member 130, a resin layer 160, and a window 20. The organic light emitting device 1000 may further include a printed circuit board (PCB) supplying a driving signal to the panel 100 and a flexible circuit board connecting the panel 100 and the printed circuit board (PCB).

[0017] The buffering member 200 may include a urethane-based material and an acryl-based material and protects the panel 100 from an external impact. For example, the buffering member 200 may be made of a sponge formed by foaming and molding urethane-based and acryl-based materials. A graded density of the buffering member 200 may be controlled according to foaming and molding conditions and a material ratio. As the density of the buffering member 200 is increased, an impact may be more quickly absorbed. Further, if the density of the buffering member 200 is decreased, for

example, an impact absorption force may be high. A buffering member 200 having low density may be appropriate for absorbing a large impact.

[0018] For adhering with the panel 100, an adhesive may be coated on one surface of the buffering member 200. The thickness of the buffering member 200 may be uniform. The buffering member 200 may be formed of at least two layers according to a structure of a supporting structure of the panel. Also, for a buffering member 200 of a single layer or multiple layers, the height or formation position of each layer structure of the buffering member 200 may be mutually different.

[0019] In the buffering member 200, the density of an edge may be higher than the density of the center. The edge of the buffering member 200 may be disposed at a position corresponding to a portion of a non-display region near a display region, and the center of the buffering member 200 may be disposed at a position corresponding to the display. The density of the buffering member 200 may be changed while having a concentration gradient or while having a clearly distinguished boundary. The buffering member 200 having higher density on the side may be disposed at the portion where the sealing member is formed. The sealing member may be a glass or a resin such that the buffering member 200 having high density may effectively and quickly absorb the impact at the portion where the sealing member is disposed, thereby improving mechanical strength. In other implementations, the buffering member 200 having the low density may be disposed on the portion corresponding to the display region such that the impact absorption force for the display region may be increased.

[0020] The buffer layer 170 may be formed on the buffering member 200. The buffer layer 170 may be formed to prevent the buffering member 200 and inner structures of an electronic device that may be inside the buffering member 200 in the organic light emitting device 1000 from reflecting and the shape of the inner structures from being transmitted and recognized outside. The buffer layer 170 may be formed of an opaque material and may have a black color.

[0021] The polarization member 130 may be between the panel 100 and the resin layer 160 to suppress reflection of external light by the panel 100. The polarization member 130 may be an absorption polarization member. The polarization member 130 may control an amount of light source light of a backlight unit (BLU) by using the polarization characteristic of the light, and may be used for improving an optical characteristic of the panel 100, the planarization member 130 may be selectively omitted if desired.

[0022] The resin layer 160 may include a transparent material such as glass or plastic, and may be hardened by ultraviolet rays (UV) irradiated from a UV ray lamp. The resin layer 160 may adhere the cover window 20 to the polarization member 130 thereby stably fixing the cover window 20, reducing the reflection of the light by a difference of refractive index, and/or smoothing the external impact.

[0023] The window 20 may include a base film and a coating layer. The base film may include polyethylene terephthalate (PET), triacetyl cellulose (TAC), polyimide (PI), polycarbonate (PC), thermoplastic polyurethane (TPU), or silicon rubber. The coating layer may be coated on the base film. The coating layer may include portions having different hardness. The coating layer may be an acryl-based hard coat or an organic/inorganic hybrid hard coat.

[0024] Next, referring to FIG. 2, a structure of the buffering member 200 of the organic light emitting device 1000 is

described. FIG. 2 illustrates a perspective view of the buffering member 200. Referring to FIG. 2, the buffering member 200 may be formed of two layers or more according to the structure of the panel supporting structure of the device. When the buffering member 200 includes a second buffering member 220 and a first buffering member 210, for example, the height or the formation position of the each layer structure of the buffering member 200 may be mutually different. A portion where the multi-buffering member of FIG. 2 is not disposed may have a structure to be connected to a PCB/FPC for driving the panel 100.

[0025] The buffering member 200 may be formed of multiple layers such as two, three, four, or more layers, thereby smoothing the impact against the panel 100 for the various shapes of structures and fixing the panel 100. The buffering member 200 may include the urethane-based and acryl-based materials and may protect the panel 100 from external impact. For example, the buffering member 200 may be made of a sponge formed by foaming and molding the urethane-based and acryl-based materials. Further, a graded density of the buffering member 200 may be controlled according to foaming and molding conditions and a material ratio. As the density of the buffering member 200 is increased, the impact may be more quickly absorbed. Further, if the density of the buffering member 200 is decreased, the impact absorption force may be higher. A buffering member 200 having low density may be appropriate for absorbing a large impact. For the adhering with the panel 100, an adhesive may be coated on one surface of the buffering member 200.

[0026] Next, referring to FIG. 3 to FIG. 6, an adhering method of the buffering member 200 of the organic light emitting device 1000 is described. FIG. 3 to FIG. 6 illustrate views showing a manufacturing process of a buffering member of an organic light emitting device. Referring to FIG. 3, a buffer layer 170 may be attached to the panel 100 of the organic light emitting device 1000, and first buffering members 210a, 210b, and 210c may be attached. The buffer layer 170 may be formed on the upper surface of the panel 100 and may be adhered to an adhesion portion of the panel 100 by using the adhesive. The buffering member 200 may be a buffering member including the dual layer and the first buffering member 210 may be adhered on the buffer layer 170.

[0027] The first buffering member 210 may include urethane-based and/or acryl-based materials and may protect the panel 100 from an external impact. For example, the first buffering member 210 may be formed of the formed and molded sponge of the urethane-based and acryl-based material. Further, the graded density of the first buffering member 210 may be controlled according to the foaming and molding conditions and the material ratio. The first buffering member 210 may include buffering members 210a and 210b that serve as the buffer in the organic light emitting device 1000, and a dummy buffering member 210c that will be removed later, as described below. The first buffering member 210 may be adhered in a cut state with respect to the dummy buffering member 210c and the buffering members 210a and 210b, which may be separated before being adhered to the buffer layer 170.

[0028] Next, referring to FIG. 4, second buffering members 220a, 220b, and 220c may be adhered on the upper surface of the first buffering member 210 of the panel 100 of the organic light emitting device 1000 formed with the first buffering member 210 of FIG. 3. The second buffering member 220 may include urethane-based and/or acryl-based material and

may protect the panel 100 from external impact. For example, the second buffering member 220 may include a sponge formed by foaming and molding the urethane-based and/or acryl-based material. The graded density of the second buffering member 220 may be controlled according to the foaming and molding conditions and the material ratio. The second buffering member 220 may use the same material as the first buffering member 210 and/or a different material.

[0029] The second buffering member 220 may be adhered on the upper surface of the first buffering member 210 of the buffer layer 170. The second buffering member 220 may include the buffering members 220a and 220b that remain in the organic light emitting device 1000, and a dummy buffering member 220c that is removed later as described below. The second buffering member 220 may be adhered in the cut state with respect to the dummy buffering member 220c and the buffering members 220a and 220b, which may be separated before being adhered to the upper surface of the first buffering member 210 on the buffer layer 170.

[0030] The height and the formation position of the first buffering member 210 and the second buffering member 220 may be different according to the structure of the panel supporting structure of the device mounted with the display panel. The shape and the size of the dummy buffering members 210c and 220c may be variously formed. In FIG. 4, for example, one example of the size of the dummy buffering members 210c and 220c of the first buffering member 210 and the second buffering member 220 is illustrated. In other implementations, the dummy buffering members 210c and 220c and the first buffering member 210 and the second buffering member 220 according thereto may have various other shapes.

[0031] An adhesive 250 may be used under the first buffering member 210 and the second buffering member 220 to adhere with the buffer layer 170 with the lower layer of each member of the first buffering member 210. An example of the organic light emitting device 1000 including the buffering member 200 formed of the dual layer is described. In other implementations, the buffering member 200 may be formed of a single layer or more than two layers.

[0032] Referring to FIG. 5, a film 270 may be adhered to the upper surface of the second buffering member 220 of the panel 100 of the organic light emitting device 1000 including the first buffering member 210 and the second buffering member 220 of FIG. 4. The film 270 may be disposed close to the upper surface of the second buffering member 220, and the dummy buffering member 220c of the second buffering member 220c. The film 270 as an element that may be removed along with the dummy buffering member 210 of the first buffering member 210 and the second buffering member 220 from the organic light emitting device 1000 may be, for example, PET. After adhering the film 270, the film 270 may be pressed by using a roller 500 to completely contact the first buffering member 210, the second buffering member 220, and the film 270 formed on the upper surface of the panel 100 of the organic light emitting device 1000 in order to not generate or minimize bubbles between each layer and the panel 100.

[0033] Next, referring to FIG. 6, among the first buffering member 210, the second buffering member 220, and the film 270 completely pressed and contacted with the panel 100 in FIG. 5, the film 270 may be separated from the panel 100 of

the organic light emitting device 1000. The dummy buffering members 210c and 220c of the first buffering member 210 and the second buffering member 220 may be adhered to the film 270 by the adhesive 250, and may be completely separated from the panel 100 and the organic light emitting device 1000 formed, for example, when the buffering member 200 is completed.

[0034] To form the buffering member 200 in the panel 100 of the organic light emitting device 1000, when simultaneously pressing the panel 100, the buffer layer 170, and the buffering member 200, for example, by using the roller 500 after forming the buffer layer 170 and the buffering member 200, the buffer layer 170 at the position where the buffering member 200 is not formed may be difficult to completely press by the roller 500. Bubbles may be easily generated between the buffer layer 170 and the panel 100. To prevent the generation of the bubbles, the buffer layer 170 may be formed on the upper surface of the panel 100 and may be completely pressed by using the roller 500, and the buffering member 200 may be formed. The buffering member 200 may be formed of the multi-layered structure according to the supporting structure of the panel 100, and in this case, for example, an adhering process may be separately used for each of buffering member 200 such that the number of processes may be increased. When the multi-layers of the buffering member 200 are sequentially formed, for example, a misalignment may be generated outside the buffering member 200.

[0035] After previously forming the dummy buffering members 210c and 220c among the buffering member 200, the buffering member 200 may be formed on part of or the entire surface of the panel 100. The film 270 may be adhered on the upper surface of the dummy buffering members 210c and 220c by using the adhesive 250. The one press process may be performed by using the roller 500 such that the buffering member 200 may be easily formed through a simple process on the panel 100 without bubble generation and additional processes. The misalignment of the buffering member 200 may also be prevented.

[0036] An organic light emitting panel 100 of an organic light emitting device 1000 is described with reference to FIG. 7 to FIG. 9. FIG. 7 illustrates a layout view of an organic light emitting device. FIG. 8 illustrates a cross-sectional view of the organic light emitting device of FIG. 7 taken along the line II-II. FIG. 9 illustrates a cross-sectional view of the organic light emitting device of FIG. 7 taken along the line III-III.

[0037] A blocking layer 111 made of a silicon oxide or silicon nitride may be formed on a substrate 110 made of transparent glass. The blocking layer 111 may have a dual-layered structure. A plurality of pairs of first and second semiconductor islands 151a and 151b that may be made of polysilicon may be formed on the blocking layer 111. The semiconductor islands 151a and 151b may respectively include a plurality of extrinsic regions including conductive impurities of an n-type or a p-type, and at least one intrinsic region that does not include conductive impurities.

[0038] In the first semiconductor island 151a, the extrinsic region may include first source and drain regions 153a and 155a and an intermediate region 1535. These may be doped with an n-type impurity and separated from each other. The intrinsic region may include a pair of first channel regions 154a1 and 154a2 between the extrinsic regions 153a, 1535, and 155a. In the second semiconductor island 151b, the extrinsic region may include second source and drain regions 153b and 155b. These may be doped with a p-type impurity

and may be separated from each other. The intrinsic region may include a second channel region **154b** between the second source and drain regions **153b** and **155b** and a storage region **157** extending from the second drain region **153b** upward.

[0039] The extrinsic region may further include lightly doped regions between the channel regions **154a1**, **154a2**, and **154b**, and the source and drain regions **153a**, **155a**, **153b**, and **155b**. The lightly doped regions may be formed at offset regions that do not include impurities. In other embodiments, the extrinsic regions **153a** and **155a** of the first semiconductor island **151a** may be doped with p-type impurities, and the extrinsic regions **153b** and **155b** of the second semiconductor island **151b** may be doped with n-type impurities. The conductive p-type impurity may be, for example, boron (B) or gallium (Ga), and the conductive impurity of the n-type may be phosphorus (P) or arsenic (As).

[0040] A gate insulating layer **140** made of, for example, a silicon nitride or silicon oxide may be formed on the semiconductor islands **151a** and **151b** and the blocking layer **111**. A plurality of gate conductors including a plurality of gate lines **121** having a plurality of first control electrodes **124a** and a plurality of second control electrodes **124b** may be formed on the gate insulating layer **140**. The gate lines **121** may transmit gate signals and may be substantially extended in the transverse direction. A first control electrode **124a** may be extended upward from the gate line **121**, thereby intersecting the first semiconductor island **151a**, and particularly overlapping the first channel regions **154a1** and **154a2**. Each gate line **121** may include an end portion having a large area for contact with another layer or an external driving circuit. When a gate driving circuit for generating gate signals is formed directly on the substrate **110**, for example, the gate lines **121** may extend and be directly connected to the gate driving circuit. A second control electrode **124b** may be separated from the gate line **121** and may overlap the second channel region **154b** of the second semiconductor island **151b**. The second control electrode **124b** may be extended thereby forming a storage electrode **127**. The storage electrode **127** may overlap the storage region **157** of the second semiconductor **151b**.

[0041] The gate conductors **121** and **124b** may be made of an aluminum-based metal of aluminum (Al) or aluminum alloys, a silver-based metal of silver (Ag) or a silver alloy, a copper-based metal of copper (Cu) or a copper alloy, a molybdenum-based metal of molybdenum (Mo) or a molybdenum alloy, chromium (Cr), tantalum (Ta), titanium (Ti), or the like. The control electrodes **124a** and **124b** may have a multi-layer structure including two conductive layers that have different physical properties from each other. One of the conductive layers may be formed using a metal having low resistivity, such as an aluminum-based metal, a silver-based metal, or a copper-based metal, in order to reduce signal delay or voltage drop. Other conductive layers may include a material having good physical, chemical, and electrical contact characteristics particularly with indium tin oxide (ITO) and indium zinc oxide (IZO), such as a molybdenum-based metal, chromium, tantalum, titanium, or the like. Examples of the combination may include a lower chromium film and an upper aluminum (alloy) film, and a lower aluminum (alloy) film and an upper molybdenum (alloy) film. In other implementations, the gate conductors **121** and **124b** may be alternatively or additionally made of various other metals and/or conductors.

[0042] Side surfaces of the gate conductors **121** and **124b** may be inclined to the surface of the substrate **110**, and an inclination angle thereof may be, for example, from about 30° to about 80°. An interlayer insulating layer **160** may be formed on the gate conductors **121** and **124b**. The interlayer insulating layer **160** may include an inorganic insulator such as a silicon nitride, a silicon oxide, and so on, an organic insulator, or an insulator having a low dielectric ratio. The dielectric constant of the insulator may be, for example, less than about 4.0, for example a-Si:C:O or a-Si:O:F compound, which may be formed through plasma enhanced chemical vapor deposition (PECVD). The interlayer insulating layer **160** may be made of an organic insulator having photosensitivity and may provide a flat surface.

[0043] The interlayer insulating layer **160** may have a plurality of contact holes **164** exposing the second control electrodes **124b**. The interlayer insulating layer **160** and the gate insulating layer **140** may have a plurality of contact holes **163a**, **163b**, **165a**, and **165b** exposing the source and drain regions **153a**, **153b**, **155a**, and **155b**. A plurality of data conductors including data lines **171**, driving voltage lines **172**, and first and second output electrodes **175a** and **175b** may be formed on the interlayer insulating layer **160**.

[0044] The data lines **171** may transmit data signals and extend in a longitudinal direction, thereby intersecting the gate lines **121**. Each data line **171** may include a first input electrode **173a** connected to the first source region **153a** through the contact hole **163a**, and may include an end portion having a large area for contact with another layer or an external driving circuit. When a data driving circuit for generating data signals is formed directly on the substrate **110**, for example, the data line **171** may extend and be directly connected to the data driving circuit.

[0045] The driving voltage lines **172** may transmit a driving voltage and extend in a longitudinal direction, thereby intersecting the gate lines **121**. Each driving voltage line **172** may include a plurality of second input electrodes **173b** connected to the second source region **153b** through the contact hole **163b**. The driving voltage line **172** may overlap the storage electrode **127** and they may be connected to each other.

[0046] The first output electrode **175a** may be separated from the data line **171** and the driving voltage line **172**. The first output electrode **175a** may be connected to the first drain region **155a** through the contact hole **165a**, and to the second control electrode **124b** through the contact hole **164**. The second output electrode **175b** may be separated from the data line **171**, the driving voltage line **172**, and the first output electrode **175a**, and may be connected to the second drain region **155b** through the contact hole **165b**.

[0047] The data conductors **171**, **172**, **175a**, and **175b** may include, for example, a refractory metal such as molybdenum, chromium, tantalum, and titanium, or alloys thereof, and may have a multi-layered structure including a refractory metal layer and a low resistance conductive layer. A multi-layered structure may include, for example, a dual layer of a chromium or molybdenum (alloy) lower layer and an aluminum (alloy) upper layer, and a triple-layer of a molybdenum (alloy) lower layer, an aluminum (alloy) middle layer, and a molybdenum (alloy) upper layer. In other implementations, the data conductor **171**, **172**, **175a**, and **175b** may be made of various other metals or conductors. Side surfaces of the data conductor **171**, **172**, **175a**, and **175b** may also be inclined to

the surface of the substrate **110**, and an inclination angle thereof may be about 30° to about 80° like the gate conductors **121** and **124b**.

[0048] A passivation layer **180** may be formed on the data conductors **171**, **172**, **175a**, and **175b**. The passivation layer **180** may be made of an inorganic material, an organic material, or a low dielectric ratio insulating material. The passivation layer **180** may have a plurality of contact holes **185** exposing the second output electrodes **175b**. The passivation layer **180** may have a plurality of contact holes exposing the end portions of the data lines **171**, and the passivation layer **180** and the interlayer insulating layer **160** may have a plurality of contact holes exposing the end portions of the gate lines **121**.

[0049] A plurality of pixel electrodes **191** may be formed on the passivation layer **180**. The pixel electrodes **191** may be physically and electrically connected to the second output electrodes **175b** through the contact holes **185**, and may be made of a transparent conductive material such as ITO or IZO, or a reflective conductor such as silver, aluminum, or alloys thereof. A plurality of contact assistants or connecting members may be formed on the passivation layer **180** and may be connected to exposed ends of the gate lines **121** and the data lines **171**.

[0050] Partitions **361** may be formed on the passivation layer **180**. The partitions **361** may define a plurality of openings enclosing edges of the pixel electrodes **191**, for example, like a bank, and may include an organic insulator or an inorganic insulator. The partitions **361** may include a photoresist including black pigments. The partitions **361** may serve as a light blocking member thereby simplifying the manufacturing process. An organic light emitting member **370** may be formed in openings **365** defined by the partitions **361** on the pixel electrode **191**. The organic light emitting member **370** as an emission layer may include an organic material uniquely emitting light of one primary color such as of three primary colors of red, green, and blue.

[0051] A common electrode **270** may be formed on the organic light emitting member **370**. The common electrode **270** may be applied with a common voltage V_{com} , and may include a transparent conductive material such as ITO or IZO or a reflective metal including calcium (Ca), barium (Ba), aluminum (Al), magnesium (Mg), aluminum (Al), silver (Ag), or the like.

[0052] In the organic light emitting device, the first semiconductor island **151a**, the first control electrode **124a** connected to the gate line **121**, the first input electrode **173a** connected to the data line **171**, and the first output electrode **175a** may form a switching thin film transistor Qs. The channel of the switching thin film transistor Qs may be formed on the pair of first channel regions **154a1** and **154a2** of the first semiconductor island **151a**. The second semiconductor island **151b**, the second control electrode **124b** connected to the first output electrode **175a**, the second input electrode **173b** connected to the driving voltage line **172**, and the output electrode **175b** connected to the pixel electrode may form the driving thin film transistor Qd. The channel of the driving thin film transistor Qd may be formed in the second channel region **154b** of the second semiconductor island **151b**. A pixel electrode **191**, an organic light emitting member **370**, and the common electrode **270** may form an organic light emitting element having the pixel electrode **191** as an anode and the common electrode **270** as a cathode, or vice versa. The storage electrode **127**, and the driving voltage line **172** and stor-

age region **157** that overlap each other via the organic light emitting member **370** interposed therebetween may form the storage capacitor Cst.

[0053] The switching thin film transistor Qs may transmit a data signal of the data line **171** in the response to a gate signal of the gate line **121**. The driving thin film transistor Qd may flow a current having a magnitude depending on a voltage difference between the second control electrode **124b** and the second input electrode **173b** according to the data signal. The voltage difference between the second control electrode **124b** and the second input electrode **173b** may also be charged to the storage capacitor Cst and may be maintained after the switching thin film transistor Qs is turned off. The organic light emitting diode OLED may emit with a strength that changes according to the magnitude of the driving current, thereby displaying a corresponding image.

[0054] By way of summation and review, a panel assembly of an organic light emitting diode (OLED) display may be formed by attaching the upper substrate and lower substrate by using a sealing member. The panel assembly may be received in a bezel. The panel assembly of the OLED display may be formed having a structure in which a space is present therein, unlike a liquid crystal display (LCD) in which liquid crystal fills the inside of the panel assembly. The space may create weakness to external impact such as from falling and the like. When an external impact such as from falling and the like is applied to the organic light emitting diode (OLED) display, for example, the impact that is applied to the bezel may be directly transmitted to the panel assembly, such that the panel assembly may be easily broken. For example, a sealing member combining the upper substrate and the lower substrate may be formed of a material that is weak against tensile stress such that the sealing member may be easily damaged by the tensile stress applied to the sealing member according to a vibration of the upper substrate and the lower substrate, for example, when externally impacted. Therefore, there may be an issue of the upper substrate and lower substrate breaking, originating from breakage of the sealing member.

[0055] In the adhering method of the buffering member to the organic light emitting device described herein, compared with a process of adhering the buffering member to a general Example embodiments have been disclosed herein, and although specific terms are employed, they are used and are to be interpreted in a generic and descriptive sense only and not for purpose of limitation. In some instances, as would be apparent to one of ordinary skill in the art as of the filing of the present application, features, characteristics, and/or elements described in connection with a particular embodiment may be used singly or in combination with features, characteristics, and/or elements described in connection with other embodiments unless otherwise specifically indicated. Accordingly, it will be understood by those of skill in the art that various changes in form and details may be made without departing from the spirit and scope of the present disclosure as set forth in the following claims.

What is claimed is:

1. A manufacturing method of an organic light emitting device, comprising:

- forming a panel displaying an image;
- adhering a buffering member including a dummy buffering member to the panel;
- adhering a film to an upper surface of the buffering member; and

- removing the film and the dummy buffering member.
2. The manufacturing method as claimed in claim 1, further comprising
pressing an upper portion of the film in a panel direction by using a roller after adhering the buffering member.
3. The manufacturing method as claimed in claim 2, further comprising
forming a buffer layer on the panel before adhering the buffering member.
4. The manufacturing method as claimed in claim 1, wherein the film includes polyethylene terephthalate (PET).
5. The manufacturing method as claimed in claim 1, wherein the buffering member includes a urethane-based or acryl-based material.
6. The manufacturing method as claimed in claim 5, wherein a density of the buffering member is the same or different according to positions thereof
7. The manufacturing method as claimed in claim 5, further comprising coating an adhesive on one surface of the buffering member facing the panel, and on a contact portion of the dummy buffering member with the film.
8. The manufacturing method as claimed in claim 5, wherein the buffering member is formed as dual layers including a first buffering member and a second buffering member, the first buffering member including a first dummy buffering member and the second buffering member including a second dummy buffering member.
9. The manufacturing method as claimed in claim 8, wherein the second buffering member is adhered to the upper surface of the first buffering member.
10. The manufacturing method as claimed in claim 9, wherein the film is adhered to the upper surface of the second buffering member.
11. The manufacturing method as claimed in claim 8, wherein the first buffering member and the second buffering member include the same material.
12. The manufacturing method as claimed in claim 8, wherein the first buffering member and the second buffering member include different materials.
13. The manufacturing method as claimed in claim 8, wherein the first buffering member and the second buffering member have the same height and formation position.
14. The manufacturing method as claimed in claim 13, wherein the first dummy buffering member and the second dummy buffering member are adhered to each other, and the dummy buffering member is adhered to the film to be removed.
15. The manufacturing method as claimed in claim 8, wherein the first buffering member and the second buffering member have different heights and formation positions.
16. The manufacturing method as claimed in claim 15, wherein the first dummy buffering member and the second dummy buffering member are adhered to each other, and the dummy buffering member is adhered to the film to be removed.
17. The manufacturing method as claimed in claim 1, wherein the buffering member includes two or more layers.

* * * * *

专利名称(译)	有机发光二极管显示器的制造方法		
公开(公告)号	US20150064819A1	公开(公告)日	2015-03-05
申请号	US14/475933	申请日	2014-09-03
[标]申请(专利权)人(译)	三星显示有限公司		
申请(专利权)人(译)	三星DISPLAY CO. , LTD.		
当前申请(专利权)人(译)	三星DISPLAY CO. , LTD.		
[标]发明人	LEE KANG YONG		
发明人	LEE, KANG-YONG		
IPC分类号	H01L51/56		
CPC分类号	H01L51/56 H01L2227/326 H01L2227/323 H01L27/3223 H01L51/5237 H01L2251/53		
优先权	1020130106239 2013-09-04 KR		
其他公开文献	US9741771		
外部链接	Espacenet USPTO		

摘要(译)

有机发光器件的制造方法可包括以下。形成显示图像的面板。包括虚拟缓冲构件的缓冲构件粘附到面板。将薄膜粘附到缓冲构件的上表面。移除胶片和伪缓冲构件。

